

Thies Wind Vane Compact TMR

S22100 / S22100H

- TMR wind direction sensor
- Output: 10-bit serial-synchronous (compatible with Ammonit Meteo-40 data loggers)
- Measurement range 0 ... 360°
- Accuracy $\pm 1^\circ$



Description

The wind direction is detected by a low-inertia wind vane. The axis of the wind vane is running in ball bearings and carries a diametrically magnetized magnet at the inner end. The angle position of the axis is sensed contact-free by a magnetic angle sensor, (TMR = Tunnel Magneto Resistance) which gives two sinus- and cosinus-dependent voltages as output signal. A connected micro-controller calculates from this voltages the wind direction in 1024 sectors ($0.35^\circ/\text{sector}$). Related to sector 1 is the wind direction $0^\circ\text{-}35^\circ$, sector 1024 corresponds to the wind direction $359.65^\circ\text{-}360^\circ$.

Benefits of Thies TMR wind vanes

Thies TMR wind vanes have a clear advantage towards potentiometer wind vanes in terms of accuracy and reliability.

Wind vane	Accuracy
Thies Compact TMR	$\pm 1^\circ$
Thies Compact Potentiometer	$\pm 2^\circ$

Additionally TMR wind vanes do not have a north gap and thanks to their solid state design they are subject to less mechanical wear than potentiometer wind vanes. TMR wind vanes do not have moving parts, except the bearings.

Dimensional Drawing

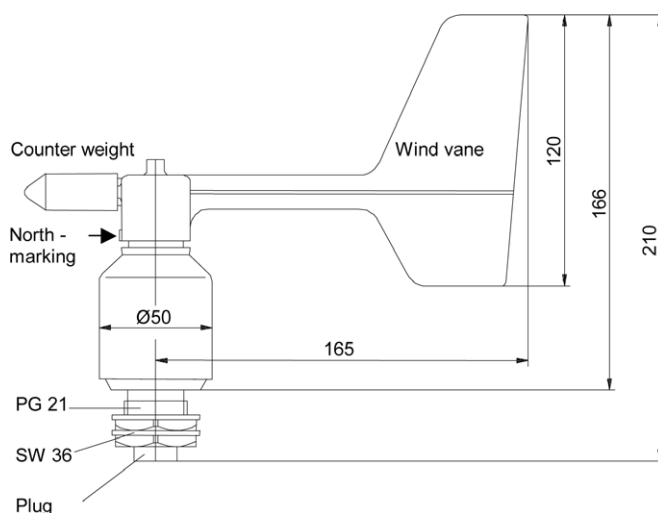

Mounting

The mounting of the sensor could be done for example at a traverse with a boring of PG 21 or in hangers with a boring of 29 mm \varnothing .

The cable or the plug is passed through the boring, and the wind direction sensor is fixed with hexagonal nut (SW36) after the north alignment.

Characteristic	Description / Value
Measurement principle	Magnetic
Measurement range	0 ... 360°
Accuracy	± 1°
Resolution	0.35°
Output	10-bit serial-synchronous (compatible with Ammonit Meteo-40 data loggers)
Survival speed	max. 80 m/s, 30 min
Operating voltage	3.3 ... 30 VDC / 24 VAC
Operating voltage heating	24 V DC/AC, max. 20W
Ambient temperature	-40 ... +70 °C
Connection	7-pole plug
Weight	approx. 0.4 kg
Protection	IP 55
Manufacturer	Thies 4.3129.60.701 (with heating) / 4.3129.70.701 (without heating)

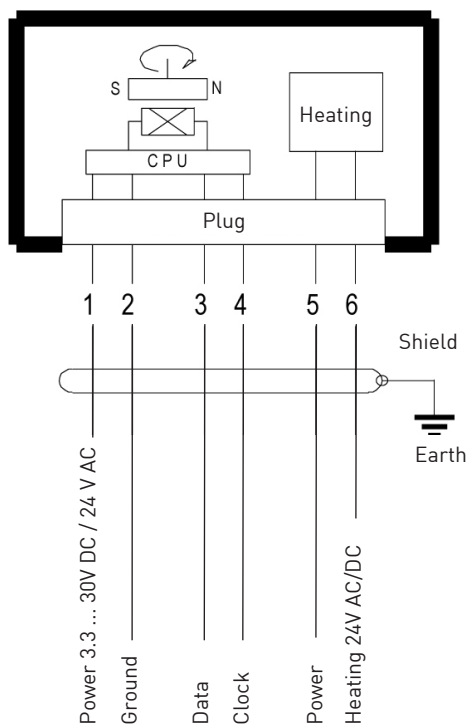

Sensor Connection

Sensor	Plug Pin No.	Ammonit Cable Wire Colour	Meteo-40 Digital	Supply Sensor
Wind Direction Data	3	white	IN	
Clock	4	blue	CLK	
Supply	1	red		12V
Ground	2	black		Main Ground
Heating	5	orange, orange		24V AC/DC
	6	purple, purple		

Cable type without heating: LiYCY 4 x 0.25mm²

Cable type with heating wires: LiYCY 8 x 0.25mm²

Connect the shield logger-sided to Ground (GND)