

Wind Vane Thies Compact POT (Plug)

S22200 / S22200H
(P6245 / P6245H)

- Potentiometric Wind Direction Transmitter
- Full Range 0 ... 360°
- High Quality Potentiometer 0 ... 2 kΩ



Measurement principle

With the help of a potentiometer the physical property is converted into an analogue resistor output signal. At zero the transducer has to pass the „north transition“ between the margins of zero and 2 kΩ. Wind direction signal conditioning and data processing in all Ammonit data acquisition systems carefully pays attention to this speciality. The wind vane can be equipped with an electronically regulated heating system in order to prevent ice from the bearings. To use this heating the connection cable must have additional cores and you should provide a sufficient power supply (mains connection).

Mounting

The sensor can easily be screwed on a piece of steel tube (outer diameter 35 mm, wall thickness 5mm) with an inner thread for PG21 or mounted to a traverse with a drill of 29 mm. The sensor cable is located weather protected in the inner tube. Please pay attention to the proper orientation of the „N“-mark towards north.

When mounting the sensor please note that you never turn the sensor at the aluminium tube because this can be opened. To fix and to loosen the lock nut the sensor must be hold with a screw spanner (SW 22) above the thread!

To avoid damage due to lightning a protection rod and proper grounding of all metal parts is to be recommended.

Maintenance

When mounted properly, the wind vane operates almost maintenance-free. Dust or dirt may clog the space between the rotating parts and the shaft. Therefore you should check for plausibility of measurement results at regular terms and clean the device if necessary. In true long-term operation (years) the bearings may be subject to wear and tear showing delayed start-up behaviour or even stand-still of the vane. Should such a defect occur we would recommend that you return the instrument for repairs.

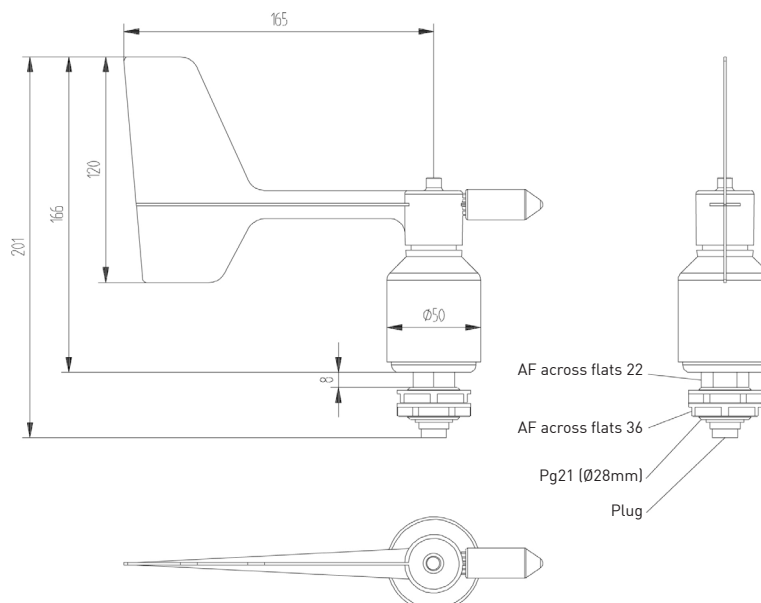

Wind Vane Thies Compact POT (Plug)

S22200 / S22200H
(P6245 / P6245H)

Characteristic	Description / Value
Measuring range	0 ... 360°
Measuring accuracy	± 2°
Survival speed	max. 80 m/s, 30 min
Ambient temperature	-40 ... +70°C
Measurement principle	Potentiometer 2 kΩ
Resolution	0.5°
Starting threshold	≤ 1 m/s according to ASTM-Standards D5366-96 ≤ 0.4 m/s according to VDI-Standard 3786 page 2
Delay distance	< 2.5 m acc. ASTM D 5366-96
Electrical supply Potentiometer	Voltage U_s : 0 ... 24 V DC Important: The supply voltage of the potentiometer must show a current limitation of max. 1 mA. An additional protective resistance is strongly recommended. Resistor R_v : 15kΩ @ supply voltage: 12 ... 15V
Heating	24 V DC/AC Power consumption: max. 20W
Connection	7-pole plug
Mast fixture	Mounted on a steel tube with an inner thread of PG21 or mounted on a traverse with a drill of 29mm
Protection	IP 55
Weight	approx. 1.10 kg
Manufacturer	Thies 4.3129.00.712 (with heating) / 4.3129.10.712 (without heating)
Accessories	Module M83501 (5V external supply POT)

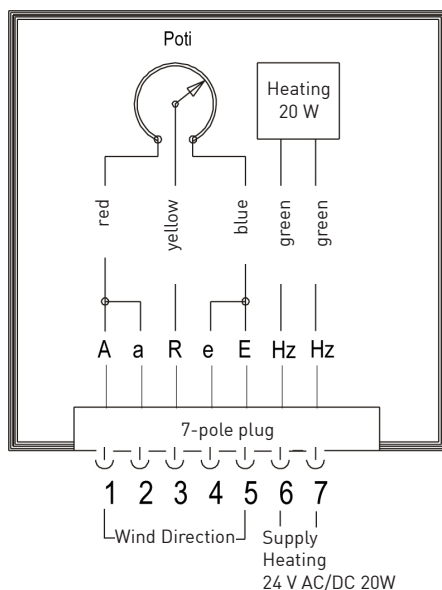

Sensor	Plug Pin No.	Ammonit Cable Wire Colour	Meteo-40 Analog Voltage	Supply Sensor
Supply Voltage	4	white	Ax	Sense
Ground	1	blue	Bx	
Wind Direction Data	3	brown	Ax+1	
Ground	1	pink	Bx+1	
Supply	5	red		12 ... 15V / 1mA R_v : 15kΩ
Ground	2	black		Main Ground
Heating	6	orange, orange		24V AC/DC
	7	purple, purple		

Cable type without heating: LiYCY 6 x 0.25mm²
 Cable type with heating wires: LiYCY 10 x 0.25mm²
 Connect the shield logger-sided to Ground (GND)

Last Modification: 02 August 2012